



General Office Brochure



SteelCrete Access Floor for General Office



■ Raised access floor system is the basis of a flexible, high performance workplace. Where air flows cleaner and easier. Where technology adapts with ease. Where the infrastructure operates more cost-effectively than ever before. And where the workplace responds and changes at the speed of business.

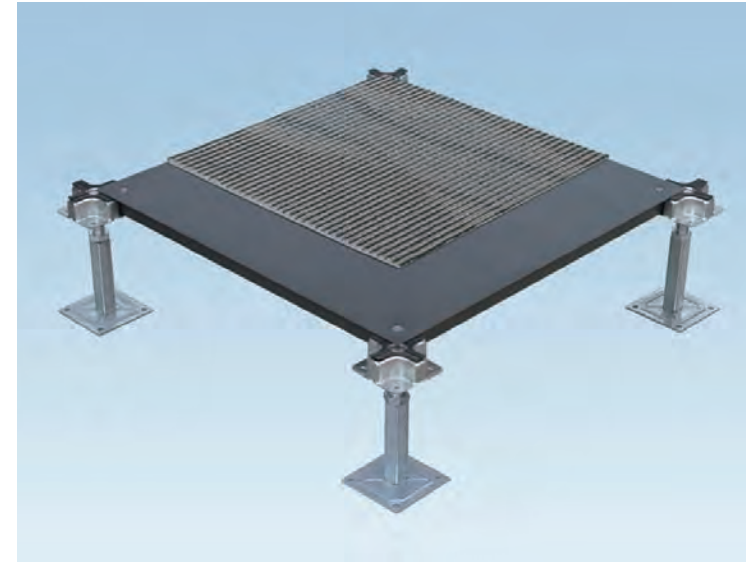

Bare Finished SteelCrete Panel + Corner Lock System

- Dimension: 600mm x 600mm or 24" x 24"
- SteelCrete panel grades: SC800, SC1000, SC1250.

Bare Finished SteelCrete Access Floor Performance Chart

General Information				Static Loads			Rolling Loads		Impact Loads
SteelCrete Panel	Top/Bottom Steel	Understructure	System Weight	Concentrated Loads	Ultimate Loads	Uniform Loads	10 Passes	10,000 Passes	
SC800B	0.7/0.7mm	Corner	8.6lbs/ft ²	800lbs	2400lbs	300lbs/ft ²	600lbs	500lbs	150lbs
		Lock	41kg/m ²	363kg	1089kg	14.35kPa	272kg	226kg	68kg
SC1000B	0.8/0.8mm	Corner	9.2lbs/ft ²	1000lbs	3000lbs	350lbs/ft ²	800lbs	600lbs	150lbs
		Lock	44kg/m ²	454kg	1363kg	16.75kPa	363kg	272kg	68kg
SC1250B	0.8/1.0mm	Corner	9.8lbs/ft ²	1250lbs	3750lbs	400lbs/ft ²	1000lbs	800lbs	150lbs
		Lock	47kg/m ²	567kg	1701kg	19.1kPa	454kg	363kg	68kg

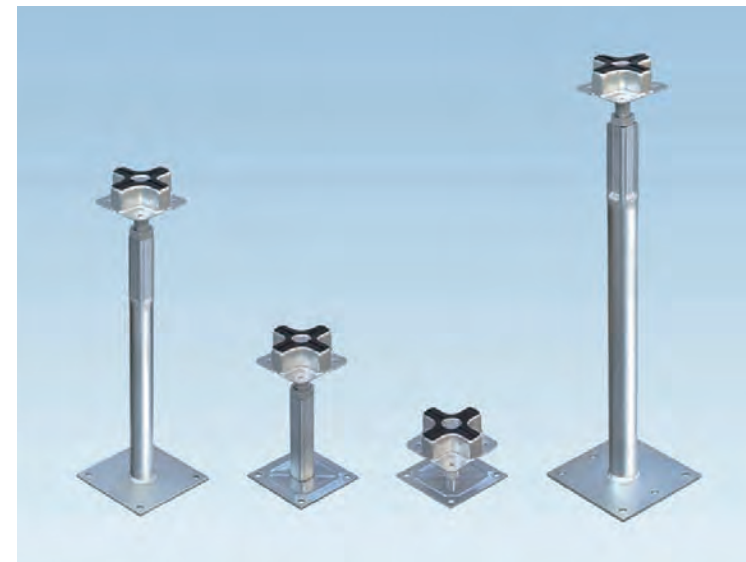

Corner Lock System

- Finished floor heights: 75mm ~ 1200mm.
- SteelCrete Access Floor is Zinc Whisker Free.



SteelCrete Access Floor for Underfloor Air Distribution



- Underfloor Air Distribution systems are a general class of air distribution systems that deliver air through diffusers in the raised access floor, with the intent of maintaining comfort and indoor air quality levels only in the occupied lower portion of space.

Bare Finished SteelCrete Access Floor Performance Chart

General Information				Static Loads			Rolling Loads		Impact Loads
SteelCrete Panel	Top/Bottom Steel	Understructure	System Weight	Concentrated Loads	Ultimate Loads	Uniform Loads	10 Passes	10,000 Passes	
SC800B	0.7/0.7mm	Bolted Stringer	9.2lbs/ft ² 44kg/m ²	800lbs 363kg	2400lbs 1089kg	300lbs/ft ² 14.35kPa	600lbs 272kg	500lbs 226kg	150lbs 68kg
SC1000B	0.8/0.8mm	Bolted Stringer	9.8lbs/ft ² 47kg/m ²	1000lbs 454kg	3000lbs 1363kg	350lbs/ft ² 16.75kPa	800lbs 363kg	600lbs 272kg	150lbs 68kg
SC1250B	0.8/1.0mm	Bolted Stringer	10.4lbs/ft ² 50kg/m ²	1250lbs 567kg	3750lbs 1701kg	400lbs/ft ² 19.1kPa	1000lbs 454kg	800lbs 363kg	150lbs 68kg

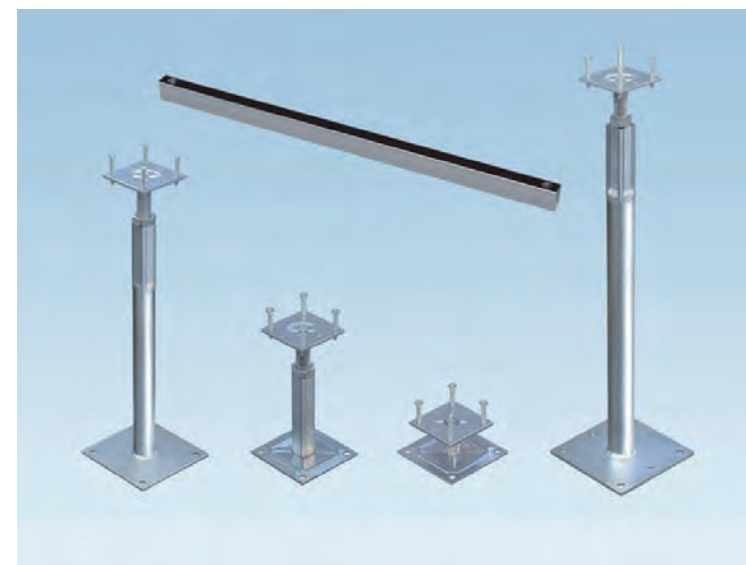
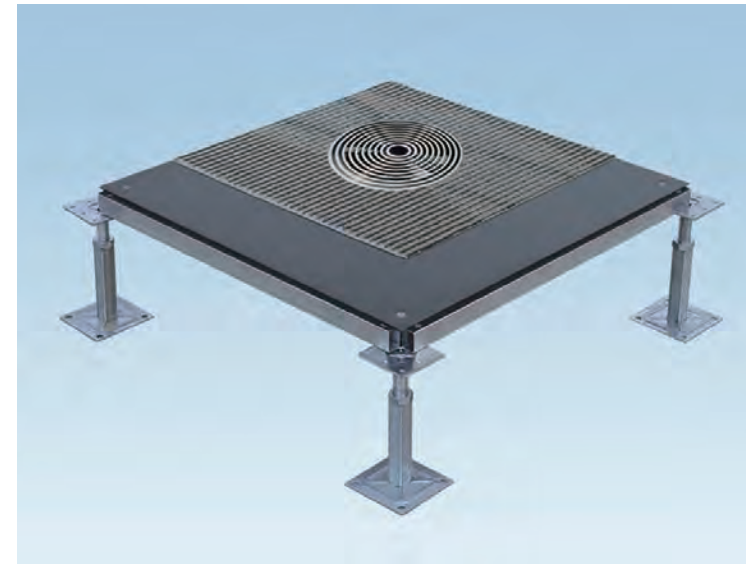

Bare Finished SteelCrete Panel + Bolted Stringer System

- Dimension: 600mm x 600mm or 24" x 24"
- SteelCrete panel grades: SC800, SC1000, SC1250.
- Used with TROX® Floor Diffuser.

Bolted Stringer System

- Finished floor heights: 150mm ~ 1200mm.
- PVC taped rectangular stringer provides excellent loading and air-tightness performance.
- SteelCrete Access Floor is Zinc Whisker Free.

TROX® Floor Diffuser

- TROX® floor diffusers type FB can provide comfortable and energy efficient air discharge into the space, by complimenting existing upward convection streams present in the occupied zone. This principle allows the local heat loads to be targeted directly.
- TROX® floor diffusers type FB can be used with SteelCrete Access Floors for Underfloor Air Distribution applications.





Dowseng Limited

Address: Xiyou Town, Laizhou City, Shandong, China 261418

Tel: +86-535-274-3443

Fax: +86-535-274-3449

Website: www.dowseng.com

Email: info@dowseng.com